

# Motorised zone valves Z-one

series 642 - 643



cert. n° 0003  
ISO 9001

01115/04 GB



## Function

The zone valves allow the automatic shut-off of circuits in heating and air conditioning systems.

The series 642 (two-way) and 643 (three-way) zone valves are equipped with a spring return actuator with a synchronous motor and auxiliary microswitch. They are therefore extremely versatile and suitable for use in both heating and air conditioning systems.

The actuator is fitted with a mechanism for rapidly clipping it onto the body of the valve which also makes it easy to remove.



## Product range

Series 642 Two-way motorised zone valve \_\_\_ sizes: 1/2", 3/4" and 1"  
Series 643 Three-way motorised zone valve \_\_\_ sizes: 1/2", 3/4" and 1"

## Technical specification

### Valve body

Materials: - body: brass, EN 12165 CW617N  
- paddle stem: stainless steel  
- paddle: EPDM

Medium: water, glycol solutions  
Max. percentage of glycol: 30%  
Temperature range: 0 – 90°C  
Peak temperature of fluid: 110°C  
Max. working pressure: 16 bar  
Connections: 1/2", 3/4", 1" F

### Actuator

Materials: - base and cover: PC G10  
Synchronous motor: Normally closed  
Supply: 230 V - 50 Hz  
Power consumption: 6,5 W; 7 VA  
Opening time: 70 – 75 s  
Closing time: 5 – 7 s  
Microswitch contacts rating: 0,8 A  
Protection class: IP 40  
Max. ambient temperature: 40°C  
Complies with Directives: 73/23/EC and 89/336/EC  
Length of power cable: 95 cm

## Dimensions

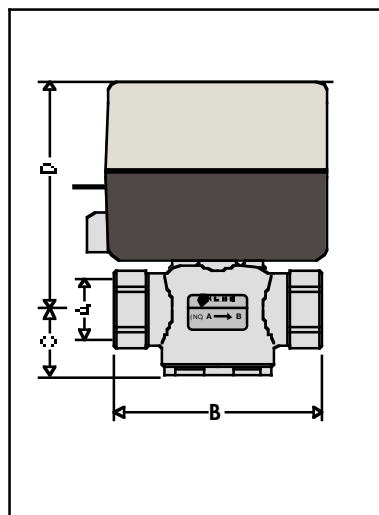

| Code   | A    | B  | C  | D  | Weight (kg) |
|--------|------|----|----|----|-------------|
| 642042 | 1/2" | 78 | 24 | 90 | 0,97        |
| 642052 | 3/4" | 78 | 24 | 94 | 0,98        |
| 642062 | 1"   | 88 | 24 | 94 | 1,10        |

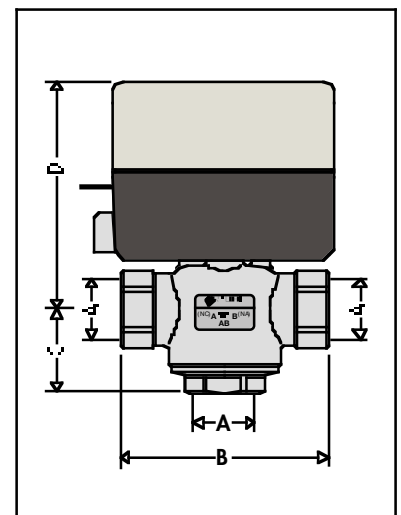

| Code   | A    | B  | C    | D    | Weight (kg) |
|--------|------|----|------|------|-------------|
| 643042 | 1/2" | 78 | 31,5 | 90,5 | 1,03        |
| 643052 | 3/4" | 78 | 31,5 | 94,5 | 1,05        |
| 643062 | 1"   | 88 | 46,5 | 94,5 | 1,20        |

## Operating principle

With the electrical supply off, the actuator keeps the valve in the closed position. When an ambient temperature thermostat or other electrical device switches the supply on, the actuator moves the paddle into the open position.

When the supply is turned off, the valve closes again due to the action of a return spring.

## Valve operating states

|                 | 2 way              | 3 way                               |
|-----------------|--------------------|-------------------------------------|
| With supply off | Passage "A" closed | "A" closed<br>"B" open<br>"AB" open |
| With supply on  | Passage "A" open   | "A" open<br>"B" closed<br>"AB" open |
| Opened manually | Passage "A" open   | "A" open<br>"B" open<br>"AB" open   |

### 642 series

#### 2-way zone valve

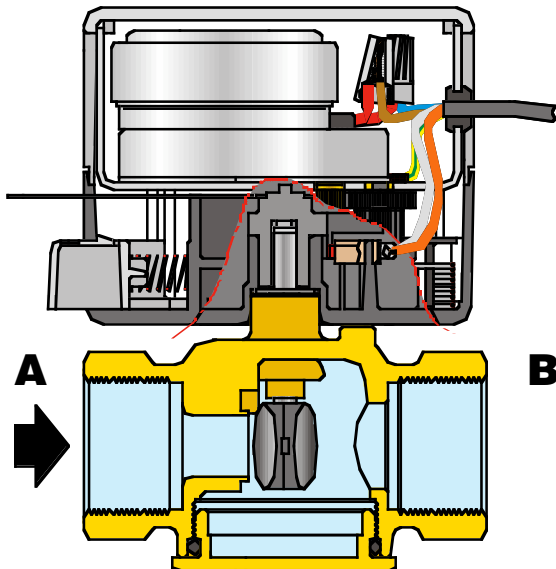

### 643 series

#### 3-way zone valve

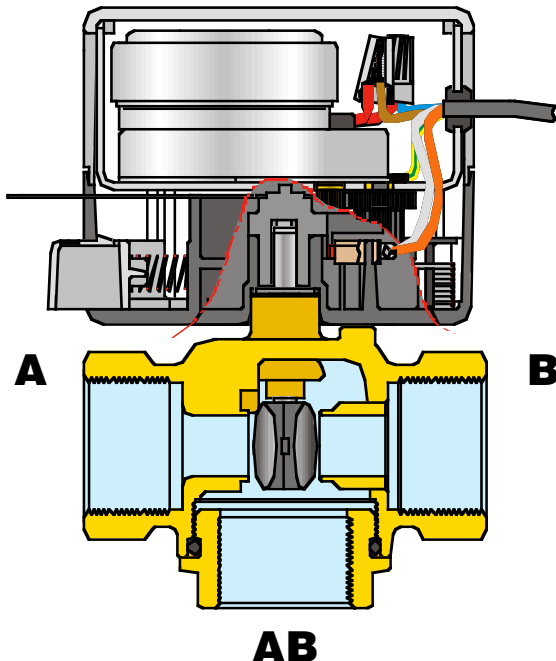

## Construction details

### • Auxiliary microswitch

The actuator is fitted with a microswitch to operate devices such as, for example, a circulating pump. The microswitch comes on when the valve is 60% open.

### • Manual opening

The valve can be opened manually by moving the lever to lock open position. When the power is restored the manual control is automatically overridden.

### • Clip on actuator

A rapid clip-on system makes it easy to remove it from the body of the valve for maintenance or replacement operations. Warning: the actuator can only be used with valve bodies 642 and 643 series.

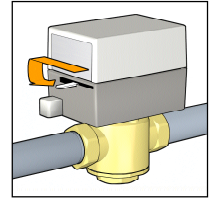

### • Operation

The actuator is fitted with a special mechanism for gradual movement of the valve paddle which prevents judder and vibration due to the inertia of the gearmotor.

## Flow curves

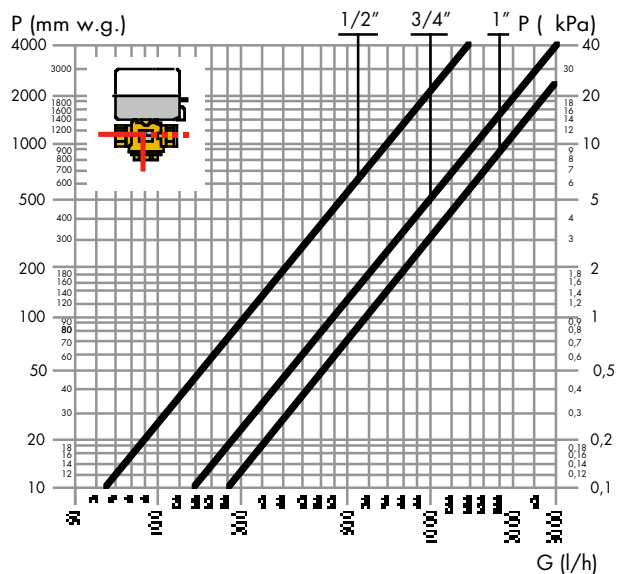
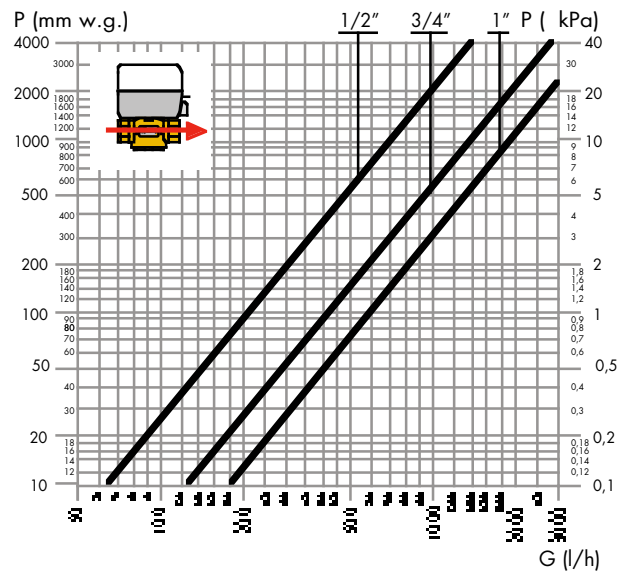

| Connection | Kv (m³/h) |         | Max. differential pressure (kPa) |
|------------|-----------|---------|----------------------------------|
|            | (2-way)   | (3-way) |                                  |
| 1/2"       | 2,5       | 2,5     | 210                              |
| 3/4"       | 4,5       | 4,5     | 150                              |
| 1"         | 6         | 6       | 100                              |

### Installation

- The valve can be fitted either vertically or horizontally, with the actuator in any position, **except upside down**.

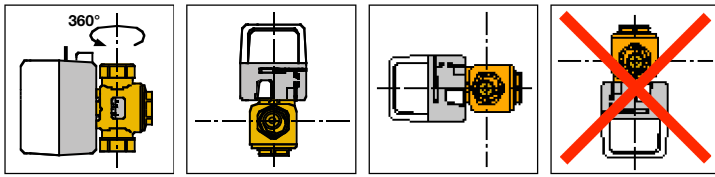

- When installed inside a casing it is important to ensure that there is adequate ventilation inside the casing itself.
- The three-way valve cannot be transformed into a two-way valve and vice versa.
- When zone valves are installed, the correct direction of flow must be observed as shown in the diagrams below.
- Two-way zone valves can be installed on both the flow and return sides; the direction of flow indicated by the arrow on the body of the valve must be observed.

#### 2-way

(with the power off, passage A is closed)

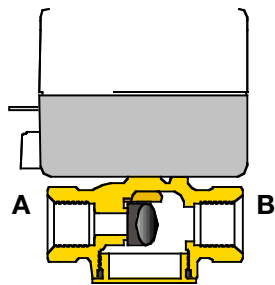

#### 2-way installed on the flow side

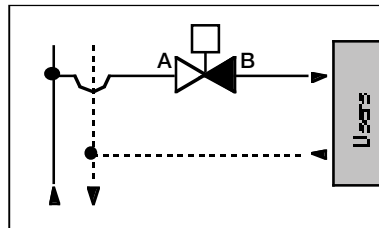

#### 2-way installed on the return side

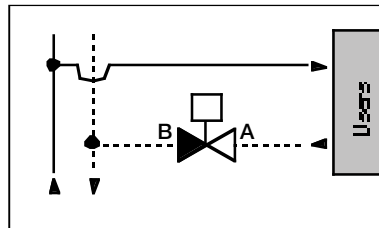

#### 3-way

(with the power off, passage A is closed)

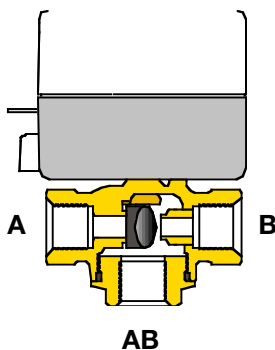

#### 3-way installed on the flow side with diverter position and ON/OFF services

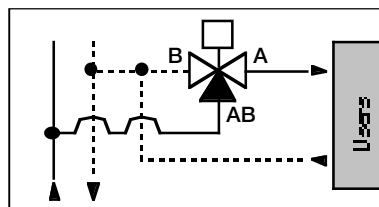

#### 3-way installed on the return side with mixer position and ON/OFF services

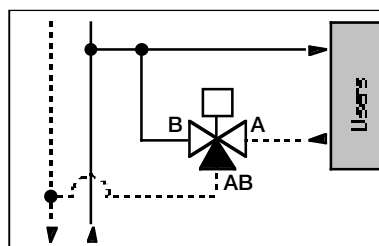

### Removal of the actuator

1. Set the lever on the side of the actuator to the open position (or to manual opening).
2. Press the open button on the side of the actuator and remove the actuator.

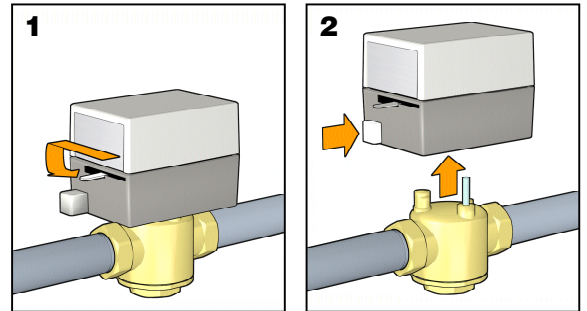

### Fitting of the actuator

1. Set the lever on the side of the actuator to the open position (or manual opening).
2. Check that the actuator is correctly positioned with respect to the valve as determined by the different dimensions of the operating stem and the locking pin.
3. Press the open button fully down. Clip on the actuator and release the button.

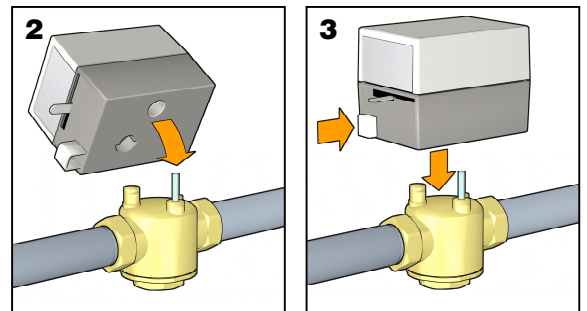

### Electrical connections

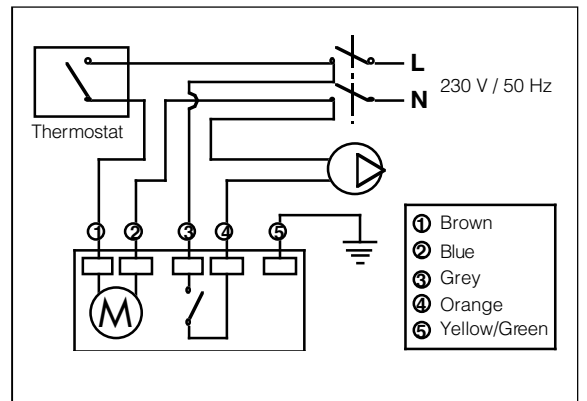

## Application diagram

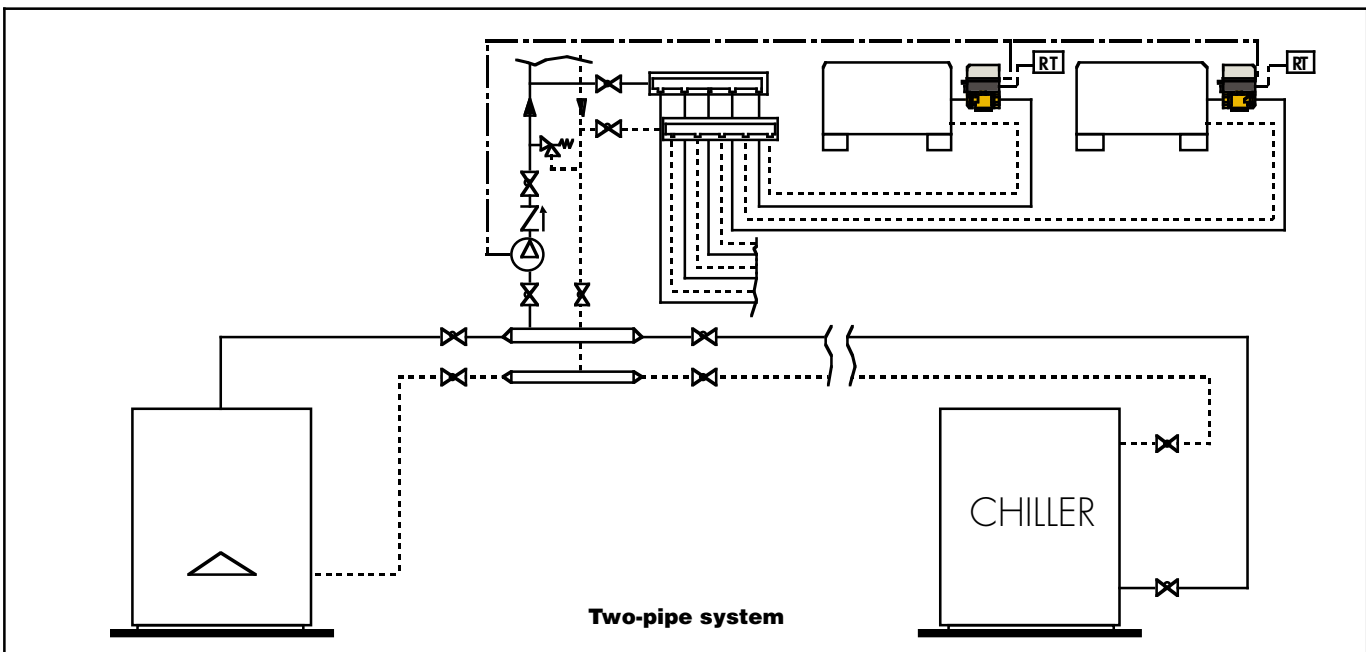
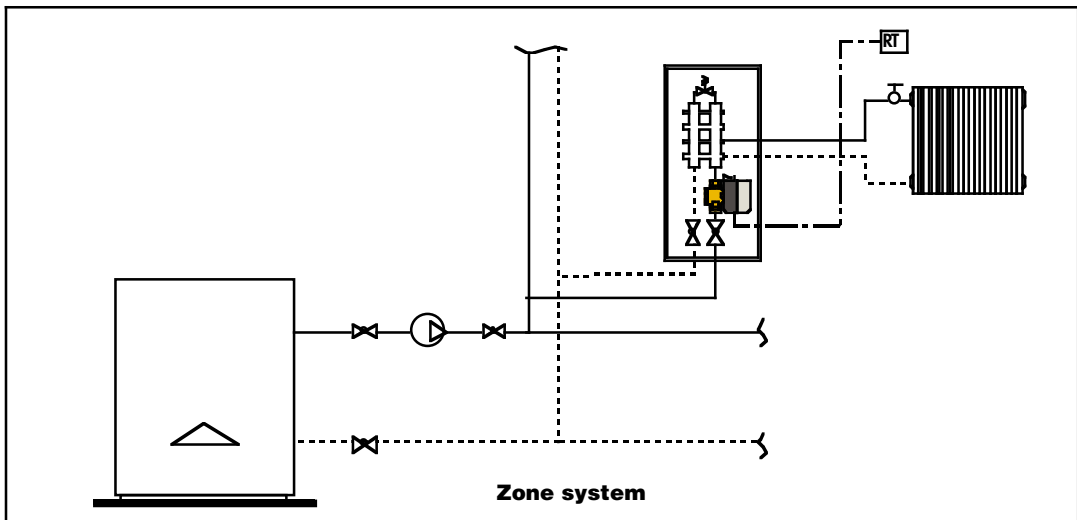
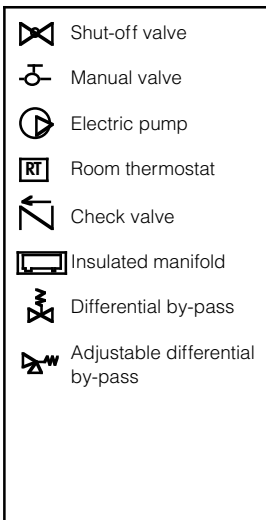

## SPECIFICATION SUMMARIES

### Series 642

Two-way motorised zone valve. Threaded connections 1/2" F (from 1/2" to 1"). Brass body. Valve stem in EPDM. Cover in reinforced polycarbonate. Temperature range: 0 – 90°C. Peak temperature of fluid: 110°C. Maximum working pressure: 16 bar. Maximum differential pressure: 210 kPa (1/2": 210 kPa, 3/4": 150 kPa, 1": 100 kPa). Maximum percentage of glycol: 30%. Actuator: Voltage 230 V (ac). Power consumption: 6,5 W; 7 VA. Maximum ambient temperature: 40°C. Opening time: 70–75 s. Closing time: 5–7 s. Fitted with auxiliary microswitch, contacts rating: 0,8 A. Protection class: IP 40.

### Series 643

Three-way motorised zone valve. Threaded connections: 1/2" F (from 1/2" to 1"). Brass body. Valve stem in EPDM. Cover in reinforced polycarbonate. Temperature range: 0-90°C. Peak temperature of fluid: 110°C. Maximum working pressure: 16 bar. Maximum differential pressure: 210 kPa (1/2": 210 kPa, 3/4": 150 kPa, 1": 100 kPa). Maximum percentage of glycol: 30%. Actuator: Voltage 230 V (ac). Power consumption: 6,5 W; 7 VA. Maximum ambient temperature: 40°C. Opening time: 70–75 s. Closing time: 5–7 s. Fitted with auxiliary microswitch, contacts rating: 0,8 A. Protection class: IP 40.

*We reserve the right to change our products and their relevant technical data, contained in this publication, at any time and without prior notice.*

